



Programmable Counter EZM-4931



- EZM-4931**
Incremental Encoder Input Programmable Counter
 - 6 digits Process (PV) and 6 digits Set (SV) Value Display
 - Operation with 2 Set Value
 - Reset , Pause and Ch-A-ChB Counting Inputs
 - Operation with Automatic and Manual Reset
 - NPN/PNP input Types
 - x1 / x2 / x4 Phase Shifting Property
 - Multiplication Coefficient, Division Coefficient and Point Position
 - Parametric , Two point (Low Scale - High Scale) and Multiplication - Division Coefficient Reading Adjustment
 - RS-232 Serial Communication with Modbus RTU Protocol
 - Input Frequency Max. 200kHz
 - Max. Input Frequency Selection

SPECIFICATIONS :

- INPUTS :**
Counting Inputs (Ch-A,Ch-B): Encoder can be connected.
Reset Input: Switch, Proximity, Capacitive sensor or encoder can be connected.
Pause Input: Switch, Proximity, Capacitive sensor or encoder can be connected.
Sensor Type Selection: NPN or PNP can be selected.
Reset Function: Automatic or Manual.
Maximum Frequency :
 INC,DEC,INC/INC,INC/DEC,UP/DOWN max.200 kHz.
Reset and Pause Input Filter : 2-50 msec (Can be adjusted in parameter.)

OUTPUT:

- Process Output :** Relay Output (5A@250V~ at Resistive Load)
SSR driver output: (Maximum 14mA, Maximum 10V ~).

SUPPLY VOLTAGE

- Supply Voltage :**
 230 V ~ 50/60 Hz (-15%; +10%) -6VA
 115V ~ (-15%; +10%) -6VA
 24V ~ 50/60 Hz (-15%; +10%) -6VA
 24V ~ (-15%; +10%) -6W
 (Must be determined in order.)

DISPLAY :

- Process Value Display :**
 EZM-4931 : 13.2 mm Red 6 digit LED Display.
Set Value Display:
 EZM-4931 : 8 mm Green 6 digit LED Display.
LED Displays : S1 (Set1 value),S2 (Set2 value),O1 / 2 (Control or Alarm Output) LEDs.

ENVIRONMENTAL RATINGS and PHYSICAL SPECIFICATIONS

- Operating Temperature:** 0...50°C
Humidity : 0-90%RH (none condensing)
Protection Class: Ip65 at Front, Ip20 at rear.
Weight: EZM-4931 : 290 gr.
Dimensions: EZM-4931 : (96 x 48mm, Depth:86.5 mm)
Panel Cut-Out: EZM-4931 : (92 x 46mm)

Electrical Wirings

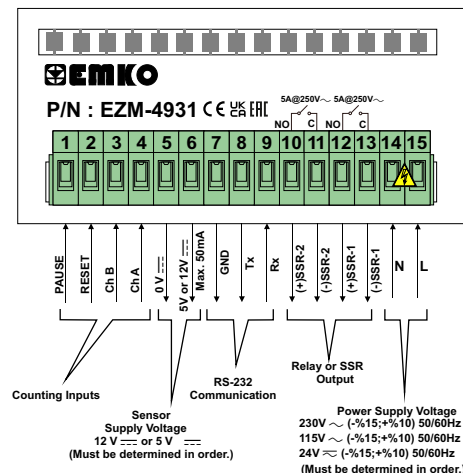

DIMENSIONS

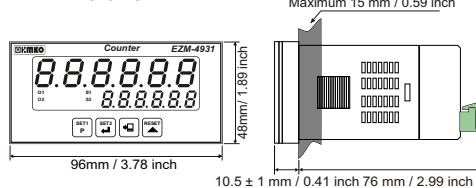

PANEL MOUNTING

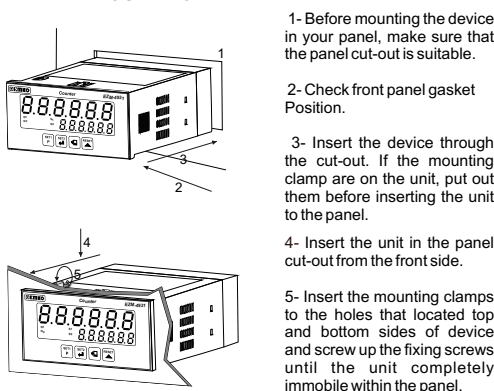

Accessing and Changing the Set Values

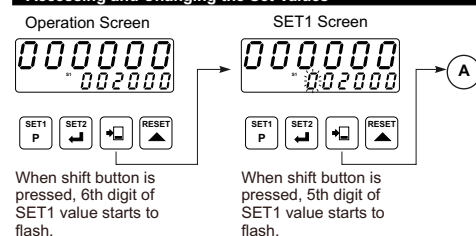

Accessing and Changing the Set Values

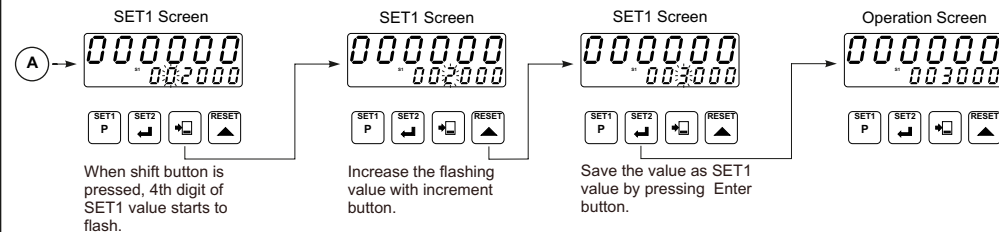

Accessing to the Program Parameters

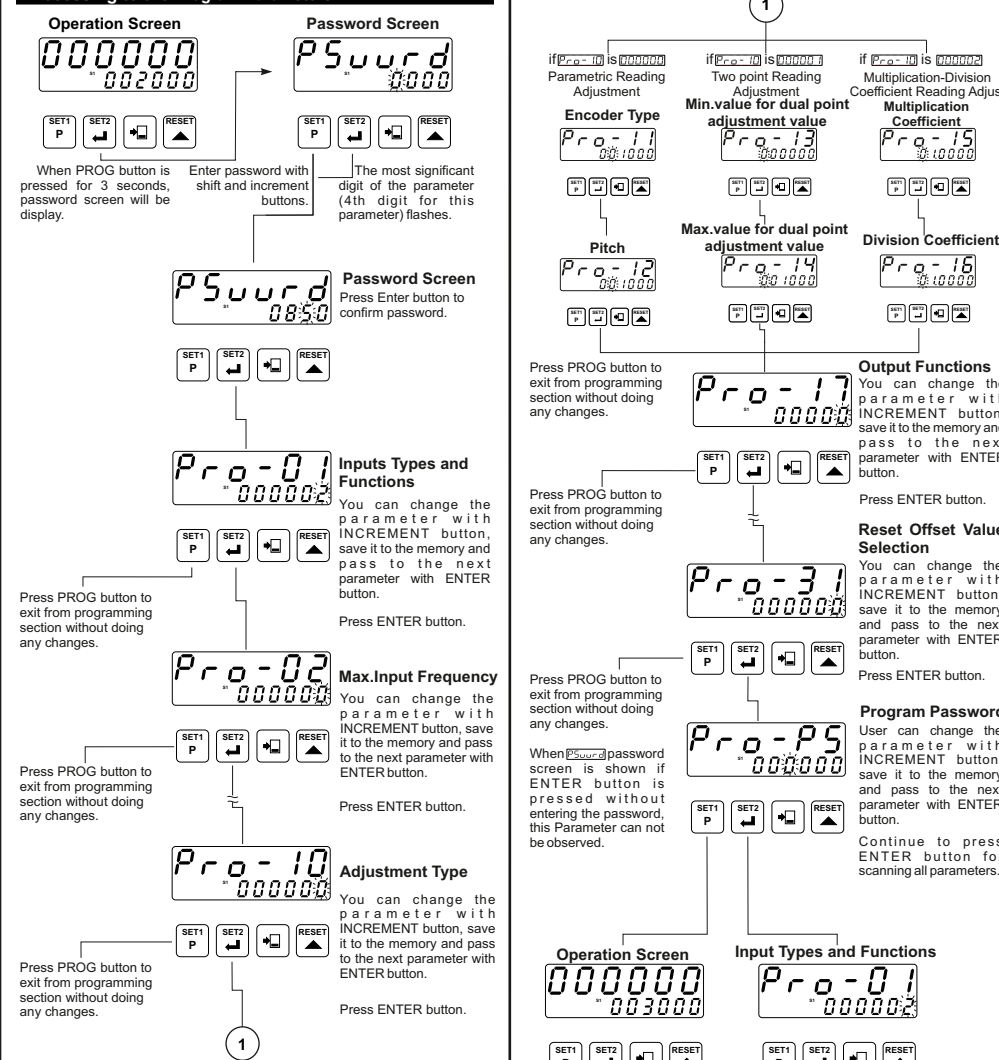

Program Parameters

Pr0-0: Input Types and Functions

- 0: x1 Phase Shifting.
- 1: x2 Phase Shifting
- 2: x4 Phase Shifting.

Pr0-02: Max. Input Frequency

- 0: 100kHz < Input Frequency < 200kHz
- 1: 50kHz < Input Frequency < 100kHz
- 2: 25kHz < Input Frequency < 50kHz
- 3: 12kHz < Input Frequency < 25kHz
- 4: 0 kHz < Input Frequency < 12kHz

Pr0-03: Filter time for Reset and Pause Input

It is used to protect against the electrical contact debounce or the signal that is less than the determined pulse time. It can be adjusted from 000002 to 000050 milliseconds.

Pr0-04: Counting Direction

- 0: Upcount (0 ⇒ Preset).
- 1: Downcount (Preset ⇒ 0).

Pr0-05: Sensor Typw Selection

- 0: NPN type sensor selection.
- 1: PNP type sensor selection.

Pr0-06: Point Position for Display

- 0: No point.
- 1: Between first and second digits .
- 2: Between second and third digits .
- 3: Between third and fourth digits.
- 4: Between fourth and fifth digits.

Pr0-07: Reset and Set protection

- 0: There is no Reset and Set protection.
- 1: Only RESET button protection is active. Actual value can not be reset by Reset button.
- 2: SET1 and SET2 can not be changed.
- 3: Full protection ; Reset protection is active, also SET1 and SET2 can not be changed.
- 4: SET1 can not be changed.
- 5: SET2 can not be changed.

Pr0-08: Reset Input Change

- 0: Reset on rising edge of Reset input.
- 1: Reset on falling edge of Reset input.

Pr0-09: Reset Offset

It can be adjusted from 000000 to 999999.

Pr0-10: Reading Adjustment Type Selection

- 0: Parametric Reading Adjustment : Encoder Type and Pitch value must be entered
- 1: Two Point Reading Adjustment : Min. Value for dual point adjustment value and Max. Value for dual point adjustment value must be entered.
- 2: Multiplication - Division Coefficient Reading Adjustment: Multiplication and Division Coefficient value must be entered.

If Pr0-10 is 000000

Pr0-11: Encoder Type

Number of pulse of Encoder is used pulse. It can be adjusted from 000001 to 010000 pulse/md.

Pr0-12: Pitch

Encoder's amount of progress on a round. It can be adjusted from 000001 to 010000 mm/md.

If Pr0-10 is 000001

Pr0-13: Min. Value for dual point adjustment value

Encoder, manually brought to the lower point after that low point value is entered for two point reading adjustment. It can be adjusted from -99999 to 999999.

Pr0-14: Max. Value for dual point adjustment value

Encoder, manually brought to the upper point after that high point value is entered for two point reading adjustment. It can be adjusted from -99999 to 999999.

If Pr0-10 is 000002

Pr0-15: Multiplication Coefficient

It can be adjusted from 000001 to 999999. Changes in this parameter is evaluated when counting starts. If this value is 0 00000 Multiplication is not performed.

Pr0-16: Division Coefficient

It can be adjusted from 000001 to 999999. Changes in this parameter is evaluated when counting starts. If this value is 0 00000 Division is not performed.

Pr0-17: Output Functions

For details, refer to the next pages.

Pr0-18: Output-1 Operation Form

- 0: Output-1 Normally non-energised.
- 1: Output-1 Normally energised.

Pr0-19: Output-2 Operation Form

- 0: Output-2 Normally non-energised.
- 1: Output-2 Normally energised.

Pr0-20: Output-1 Pulse Time

It determines how long Output-1 will be active. It can be adjusted from 000000 to 009999 seconds. If it is 000000 second, then it operates indefinitely.

Pr0-21: Output-2 Pulse Time

It determines how long Output-2 will be active. It can be adjusted from 000000 to 009999 seconds. If it is 000000 second, then it operates indefinitely.

Pr0-22: Max Set Value

Maximum value for Set Values.

It can be adjusted from 000000 to 999999.

Pr0-23: Min Set Value

Maximum value for Set Values.

It can be adjusted from 000000 to 999999.

Pr0-24: Display Type Selection

- 0: Display value is incremental encoder counter value.
- 1: Display value is calculated value.

Pr0-25: Saving Count Value (Power down back-up)

- 0: Count value is saved to memory when power is disconnected and restored on power up.
- 1: Count value is not saved to memory when power is disconnected.

Pr0-26: Slave Address

Device address for serial communication bus.

t can be adjusted from 000001 to 000247.

Pr0-27: Communication Parity Selection

- 0: No Parity.
- 1: Odd Parity.
- 2: Even Parity.

Pr0-28: Baud Rate

- 0: 4800 Baud Rate.
- 1: 9600 Baud Rate.
- 2: 19200 Baud Rate.
- 3: 38400 Baud Rate.

Pr0-29: Communication Stop Bit Selection

- 0: 1 Stop Bit.
- 1: 2 Stop Bits.

Pr0-30: Return to Factory Settings

Restore all settings to factory default. This parameter has a special password.

Pr0-31: Reset Offset Value Selection

- 0: Pro-09 parameter is adjusted as a reset offset value.
- 1: SET-1 value is adjusted as a reset offset value.
- 2: SET-2 value is adjusted as a reset offset value.

Pr0-35: Program Password

It is used for accessing to the program parameters. It can be adjusted from 000000 to 999999. If it is 000000 there is no password protection while accessing to the parameters.

Pr0-17: Output Functions

- 0: Manual Reset-0: Device continues to count till manual reset is applied. When Manual reset happens, count value becomes Reset Offset value. Outputs are not active in this parameter.

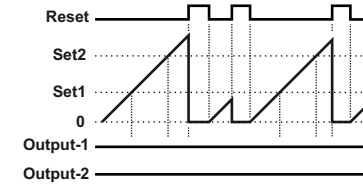

- 1: Manual Reset-1: Device continues to count till manual reset is applied. When count value reaches to SETs value, Outputs become active. Output-2 pulse time Pr0-21 is not considered.

Counting direction : 0 ⇒ P (Upcount)

Pr0-04 = 000000

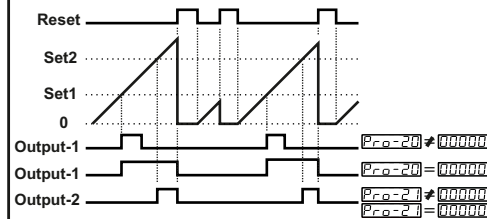

Counting direction : P ⇒ 0 (Downcount)

Pr0-04 = 000001

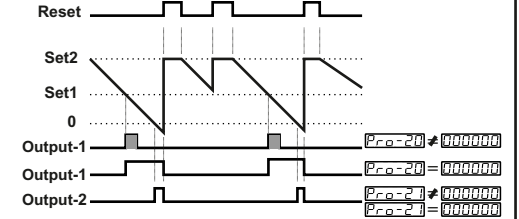

- 2: Manual Reset-2: Counting does not continue over SET2 value. For starting to count manual reset input must be active. Output-2 pulse time Pr0-21 is not considered.

Counting direction : 0 ⇒ P (Upcount)

Pr0-04 = 000000

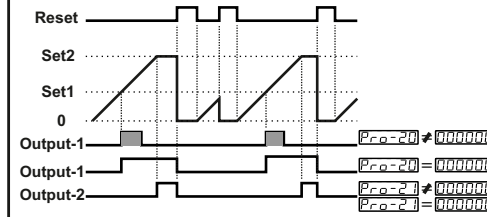

Counting direction : P ⇒ 0 (Downcount)

Pr0-04 = 000001

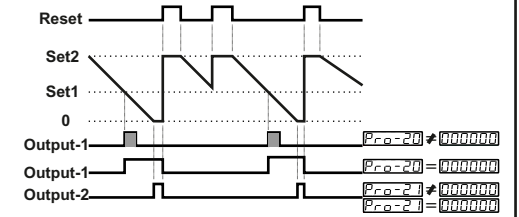

- 3: Manual Reset-3: Device continues to count till manual reset is applied. (Output-2 pulse time Pr0-21 is not considered.)

Counting direction : 0 ⇒ P (Upcount)

Pr0-04 = 000000

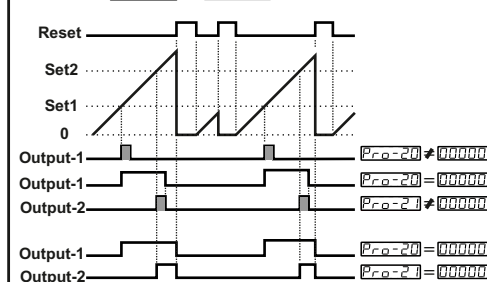

Counting direction : P ⇒ 0 (Downcount)

Pr0-04 = 000001

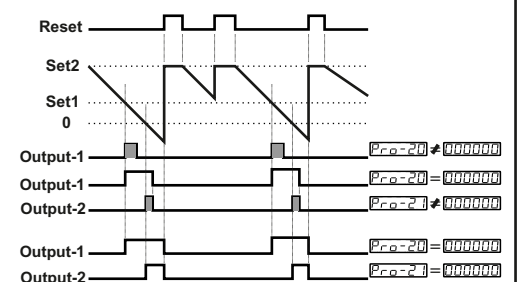

4:Manual Reset-4:Device continues to count till manual reset is applied.
 (P_{ro-20} and P_{ro-21} are not considered.)

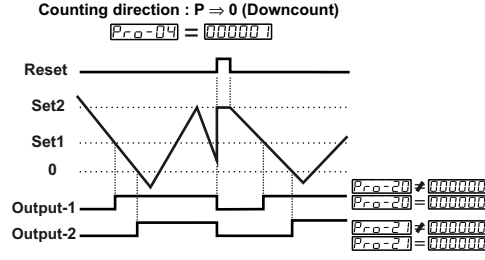
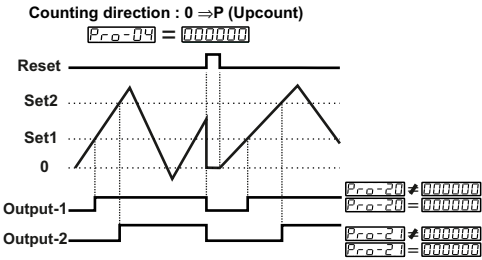

5:Manual Reset-5:Device continues to count till manual reset is applied.
 (P_{ro-20} and P_{ro-21} are not considered.)

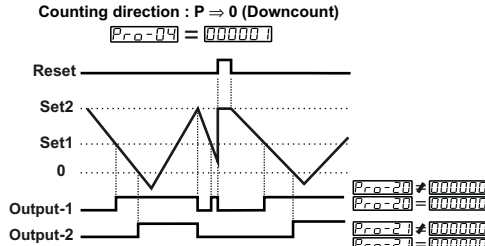
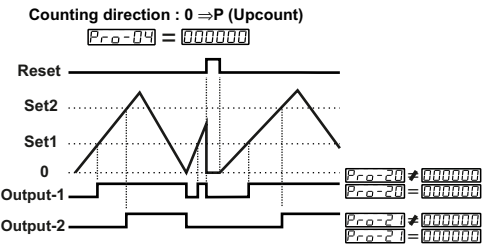

6:Manual Reset-6:Device continues to count till manual reset is applied.
 (P_{ro-20} and P_{ro-21} are not considered.)

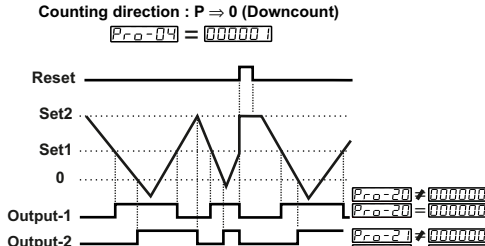
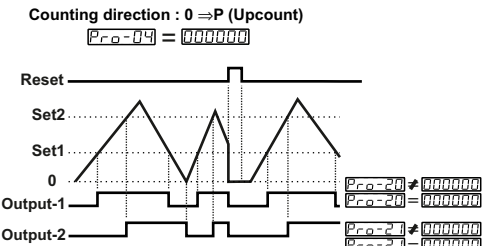

7:Manual Reset-7:Device continues to count till manual reset is applied.
 (P_{ro-20} and P_{ro-21} are not considered.)

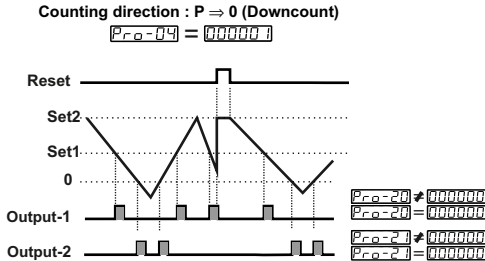
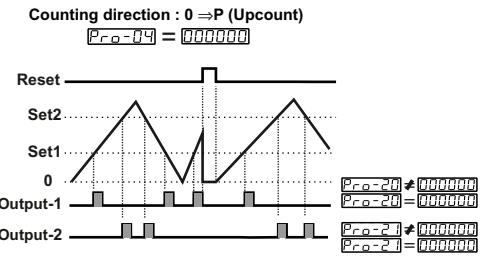

8:Automatic Reset-1: Device continues to count till manual reset is applied.
 Output-2 pulse time P_{ro-21} is not considered.

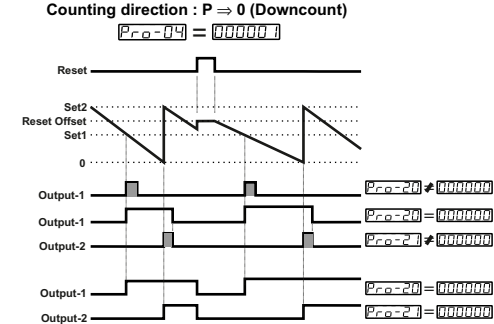
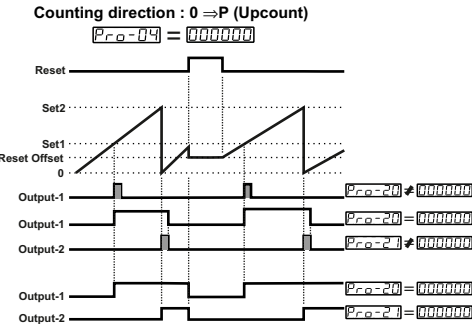

9:Automatic Reset-2:

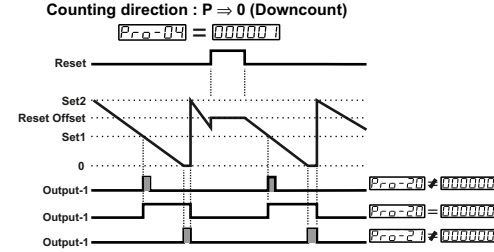
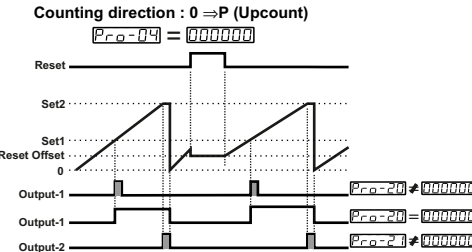

10:Automatic Reset-3:

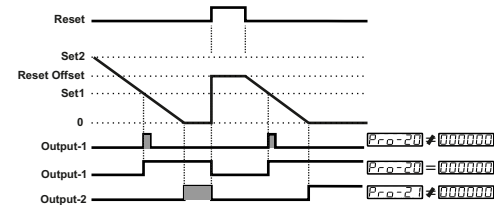
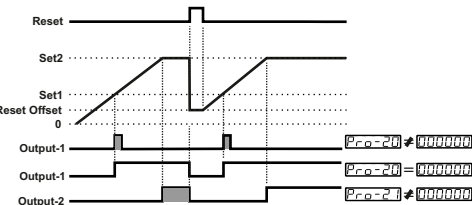
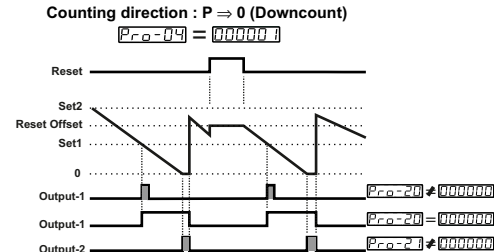
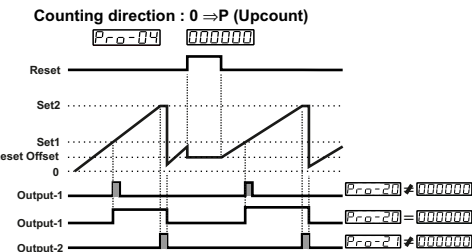

11: Automatic Reset-4:

Counting direction : 0 ⇒ P (Upcount)

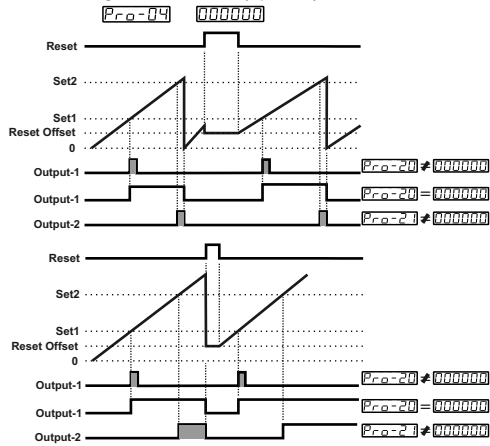

Counting direction : P ⇒ 0 (Downcount)

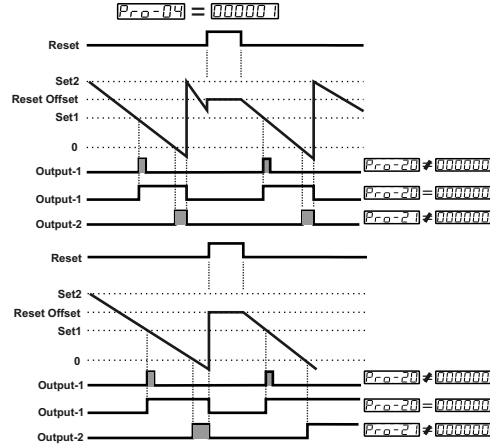

12: Automatic Reset-5: (Pr0-20 and Pr0-21) are not considered.)

Counting direction : 0 ⇒ P (Upcount)

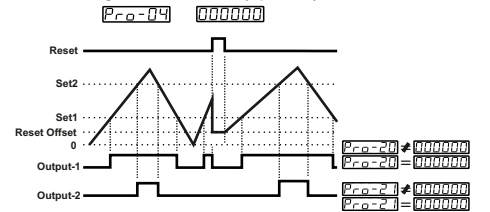

Counting direction : P ⇒ 0 (Downcount)

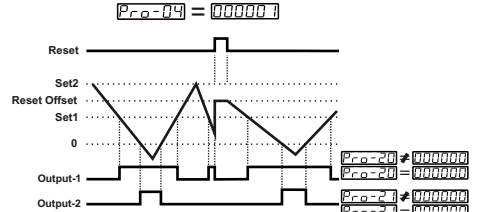

13: Manual Reset: Counting does not continue over SET2 value. For starting to count manual reset input must be active. Output-2 pulse time (Pr0-21) is not considered.

Counting direction : 0 ⇒ P (Upcount)

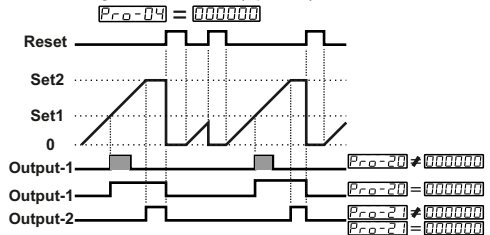

Counting direction : P ⇒ 0 (Downcount)

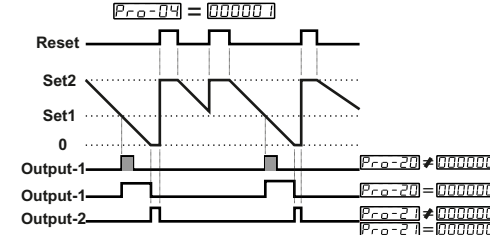

Failure Messages in EZM-4931 Programmable Counter

1-If the password is not , user can access to the parameters without entering the password and by pressing ENTER button. User can see all parameters except for programming password parameter (Pr0-P5) but user can not do any changes in parameters. If password is entered for accessing to the parameters correctly, most significant digit of the parameter flashes. But if the password is not entered, flashing of the most significant digit is not realised.

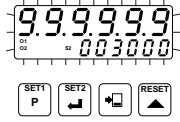

2-If Actual Value is flashing; It appears if any of the count value is bigger than the maximum count value. To remove this warning and reset the count value press RESET button.

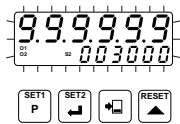

3-If Actual Value is flashing and counting is stopped; It appears if any of the count value is lower than the minimum count value. To remove this warning and reset the count value press RESET button.

Installation



Before beginning installation of this product, please read the instruction manual and warnings below carefully.

- In package.
- One piece unit
- Two pieces mounting clamp
- One piece instruction manual

A visual inspection of this product for possible damage occurred during shipment is recommended before installation. It is your responsibility to ensure that qualified mechanical and electrical technicians install this product.

If there is danger of serious accident resulting from a failure or defect in this unit, power off the system and the electrical connection of the device from the system.

The unit is normally supplied without a power switch or a fuse. Use power switch and fuse as required.

Be sure to use the rated power supply voltage to protect the unit against damage and to prevent failure.

Keep the power off until all of the wiring is completed so that electric shock and trouble with the unit can be prevented.

Never attempt to disassemble, modify or repair this unit. Tampering with the unit may result in malfunction, electric shock or fire.

Do not use the unit in combustible or explosive gaseous atmospheres. During the equipment is putted in hole on the metal panel while mechanical installation some metal burrs can cause injury on hands, you must be careful.

Montage of the product on a system must be done with it's mounting clamp. Do not do the montage of the device with in appropriate mounting clamp. Be sure that device will not fall while doing the montage.

It is your responsibility if this equipment is used in a manner not specified in this instruction manual.

Warranty

EMKO Elektronik warrants that the equipment delivered is free from defects in material and workmanship. This warranty is provided for a period of two years. The warranty period starts from the delivery date. This warranty is in force if duty and responsibilities which are determined in warranty document and instruction manual performs by the customer completely.

Maintenance

Repairs should only be performed by trained and specialized personnel. Cut power to the device before accessing internal parts. Do not clean the case with hydrocarbon-based solvents (Petrol, Trichlorethylene etc.). Use of these solvents can reduce the mechanical reliability of the device. Use a cloth dampened in ethyl alcohol or water to clean the external plastic case.

Other Informations

Manufacturer Information:

Emko Elektronik Sanayi ve Ticaret A.Ş. Organize Sanayi Bölgesi, (Fethiye OSB Mah.) Turkuaz Cd. No:15 16215 NİLÜFER/BURSA
Tel : +90 224 261 1900
Fax : +90 224 261 1912

Repair and maintenance service information:

Emko Elektronik Sanayi ve Ticaret A.Ş. Organize Sanayi Bölgesi, (Fethiye OSB Mah.) Turkuaz Cd. No:15 16215 NİLÜFER/BURSA
Tel : +90 224 261 1900
Fax : +90 224 261 1912

Order Information

EZM-4931 (96x48 1/8 DIN)	A	B	C	D	E	/	F	G	H	I	/	U	V	W	Z
		00			/		0	/				0	0	0	

A Supply Voltage
2 24V ~ (-%15;+%10), 50/60Hz
4 115 V ~ (-%15;+%10), 50/60 Hz
5 230 V ~ (-%15;+%10), 50/60 Hz

D Serial Communication
0 No
1 RS-232

E Output-1
00 No
01 Relay Output (5A@250V~at Resistive Load)
02 SSR Driver Output (Maksimum 14mA,10V ---)

FG Output-2
00 No
01 Relay Output (5A@250V~at Resistive Load)
02 SSR Driver Output (Maksimum 14mA,10V ---)

U Encoder Supply Voltage
0 12V ---
1 5V ---

All order information of EZM-4931 programmable counter is given on the table at above. User may form appropriate device configuration from information and codes that at the table and convert it to the ordering codes.

Firstly, supply voltage then other specifications must be determined. Please fill the order code blanks according to your needs. Please contact us, if your needs are out of the standards.



- Symbol Means Vac ~
- Symbol Means Vdc ---
- Symbol Means Vac and Vdc ≈

EMKO Thank you very much for your preference to use Emko Elektronik products, please visit our Your Technology Partner Web page to download detailed user manual.
www.emkoelektronik.com.tr